

**PAINT SPRAY BOOTH DATA FORM -  
SUPPLEMENT TO APPLICATION FOR APPROVAL (AIR & NOISE)  
FOR AUTOMOTIVE REFINISHING OPERATIONS**

**General Information:**

1. This form is to accompany all Applications for Automotive Refinishing Paint Spray Booth(s) and associated equipment. It does not replace the Application form for a Certificate of Approval for Air & Noise.
2. The information contained in this form and the required supporting drawings are used to process an application for a Certificate of Approval. Please be advised that all sections MUST be filled out as indicated. Incomplete forms will be RETURNED to the Applicant.
3. The Ministry is currently undertaking a compliance assistance pilot project with the autobody refinishing sector. The project is being delivered through an agreement with the Hamilton District Autobody Repair Association (HARA). If you require assistance in preparing a Contaminant Emission Summary and Dispersion Modelling Report, and using the Regulation 346 Dispersion Model, you may wish to contact HARA at (905) 664-7888 or 1-866-309-4272 (HARA). You can also visit their website at <http://www.ciia.com/>

The yellow pages of your telephone book provides a list of environmental consultants who may be qualified in preparing an Emission Summary and Dispersion Modelling Report (ESDM) or the manufacturer of your paint booth may be able to provide you with assistance or direction in obtaining qualified technical assistance.

4. Application forms and supporting documentation are available from the Environmental Assessment and Approvals Branch toll free at 1-800-461-6290 (locally at 416-314-8001), from your local District Office of the Ministry of the Environment, and in the "Publications" section of the Ministry of the Environment website at [www.ene.gov.on.ca](http://www.ene.gov.on.ca).
5. Questions regarding completion and submission of this data form should be directed to the Environmental Assessment and Approvals Branch, 2 St. Clair Avenue West, Floor 12A, Toronto, Ontario, M4V 1L5, 1-800-461-6290 or (416) 314-8001, or to your local District Office of the Ministry of the Environment.

**INFORMATION FOR PROPONENTS  
APPLYING FOR A CERTIFICATE OF APPROVAL (AIR)  
FOR A PAINT SPRAY BOOTH**

Section 9 of the Ontario *Environmental Protection Act*, R.S.O. 1990 (Act) requires that anyone who constructs, alters, replaces or extends anything that may discharge a contaminant to the natural environment, other than water, obtain a Certificate of Approval from the Director before the construction, alteration, replacement or extension takes place. As a result, no person may install and operate equipment, such as a paint spray booth, that discharges to the atmosphere without first obtaining a Certificate of Approval. Detailed information on approval requirements and procedures are contained in a separate document entitled "Guide for Applying for Approval (Air), Section 9, Environmental Protection Act, R.S.O. 1990, Environmental Assessment and Approvals Branch, November 2005". This document is available on the Ministry of Environment's web site ([www.ene.gov.on.ca](http://www.ene.gov.on.ca)) or can be obtained by contacting a client services representative at 1-800-461-6290 or (416) 314-8001.

**EMISSIONS and CRITERIA FOR APPROVAL - PAINT SPRAY BOOTHS**

The anticipated contaminants emitted to the atmosphere from a paint spray booth are paint over-spray, solvent components, and noise. Impacts from paint solvent emissions are required to comply with contaminant-specific limits at a point of impingement (Ontario Regulation 419/05: Air Pollution – Local Air Quality), where a typical point of impingement location is interpreted to be a nearby air intake and/or a property line.

However, in addition to compliance with the point of impingement limits, Section 14 of the Ontario Environmental Protection Act prohibits the causing of an adverse effect, such as an odour. It is also expected that the operation of an approved paint spray booth will include efforts to avoid adverse effects through consideration of effective dispersion of the contaminants (i.e., appropriate stack location and exit velocities) and consideration of neighbours in the vicinity of the paint spray booth.

Some proposed installations may require a detailed noise assessment, depending upon the size of the exhaust fan and proximity to residential receptors. The following provides a summary of the regulatory and guideline assessment criteria for a proposed paint spray booth:

Regulatory Criteria: Compliance with the point of impingement limits administered by Ontario Regulation 419/05;

Guideline Criteria: - Compliance with the point of reception limits for noise under guideline Publications NPC-205 and NPC-232, and for vibration guidelines under NPC-207;  
- Unimpeded vertical discharge of the contaminants from the stack with an exit velocity of at least 12 metres per second; and  
- For dry filter pad installations (for exhaust), an effective combined filter area of at least  $0.4 \times \text{booth width} \times \text{booth height}$ .

Deviation from the recommended stack head designs, vertical discharge and/or exit velocity criteria must include a detailed analysis demonstrating that compliance will be achieved.

## KEY DEFINITIONS

**Air Intake Opening** – Refers to the building air intakes, openable windows, or doorways, on any residential, commercial or industrial building occupied by individuals not associated with the application.

**Point of Impingement** – means any point on the ground or on a receptor, such as a nearby building, located outside the company’s property boundaries at which the highest concentration of a contaminant caused by the maximum aggregate emission of that contaminant from the facility is expected to occur.

**Point of Reception** – means any point on the premises of a person where sound or vibration originating from other than those premises is received.

For the purpose of approval of new sources, including verifying compliance with section 9 of the *Environmental Protection Act*, the point of reception may be located on any of the following existing or zoned for future use premises: permanent or seasonal residences, hotels/motels, nursing/retirement homes, rental residences, hospitals, camp grounds, and noise sensitive buildings such as schools and places of worship. For equipment/facilities proposed on premises such as nursing/retirement homes, rental residences, hospitals and schools, the point of reception may be located on the same premises.

Note: Additional definitions are found at the end of this application form.

## 1.0 GENERAL INFORMATION

### 1.1 Company Information

Company (legal) Name: \_\_\_\_\_

(Fill in the legal name of your company and provide a copy of the document showing the legal name.  
e.g. For a corporation, a copy of the page of the articles of incorporation must be provided, showing the legal name.  
For a sole proprietor, a copy of the owner's birth certificate or driving license should be submitted.)

Business Name: \_\_\_\_\_, if applicable

(Fill in the business name of the company if it is different from the legal name above.  
Provide a copy of the document showing the business name.  
e.g. a copy of the business permit or business registration)

Company Address: \_\_\_\_\_  
(Fill in the company address)

Facility Address: \_\_\_\_\_  
(Fill in facility address if different from the company address)

### 1.2 Zoning

Adjacent Land-Use as per local zoning up to 100 metres from the facility (e.g. Industrial, Commercial, Residential, Institutional, Agricultural, etc)

North:                      East:                      South:                      West:

Please submit a copy of the zoning map.

(A copy of the zoning map can be obtained from the Planning division of the local municipal government)

### 1.3 Equipment Installation

Is the equipment installed?  
(Has the equipment been installed or operated?)

Yes       No

Is this application a result of an order?  
(Was an order issued to your company to apply for a  
Certificate of Approval (Air) ?)

Yes       No

If yes, provide the Provincial Order Number:  
(Fill in the Provincial Order number as shown on the order issued to you.)

*If yes, provide a copy of the Provincial Order*

## 2.0 FACILITY OPERATION

### Equipment Operation (check all that apply):

(Indicate whether the paint spray booth is operated during the following three periods)

Day (07:00-19:00)       Evening (19:00-23:00)       Night (23:00-07:00)

Does the equipment operate more than 10 hours in any 7-day period?     Yes     No  
 (For EBR requirements, indicate if the paint booth is used more than 10 hours in a week)

Maximum operation during any one-hour period (minutes): \_\_\_\_\_  
 (In any one hour period, indicate the maximum time that the equipment would be operating continuously)

## 3.0 DRAWINGS

Provide up-to-date site plan and elevation drawing(s) drawn-to-scale or fully dimensioned, showing the following:

Site Plan Drawing	Elevation Drawing
<input type="checkbox"/> Property lines <input type="checkbox"/> On-site buildings <input type="checkbox"/> Neighbouring buildings <input type="checkbox"/> Booth stack location(s) <input type="checkbox"/> “Air Intake Openings” of neighbouring units (e.g. doors, windows and/or fresh air intakes)	<input type="checkbox"/> Site Buildings <input type="checkbox"/> Booth Stacks (s)

## 4.0 EQUIPMENT INFORMATION

### 4.1 Equipment Summary Table (Fill in the following table for all paint spray booths, prep stations, paint mix room, etc. at the facility)

Source Identifier (Identification for the equipment)	New or Existing (Indicate whether the equipment has a C of A approval)	Type <sup>(1)</sup>	Dimensions (m) (Provide inside dimension of the booth in metres)	Filtration		Type of Stack head Design <sup>(4)</sup>	Exit Velocity <sup>(5)</sup> (m/s)
				Exhaust dry filter Area <sup>(2)</sup>	Water wash System <sup>(3)</sup>		
			Length (L): Width (W): Height (H): Filter Area Required: $0.4 \times W \times H = \text{___ m}^2$	Filter area ___ m <sup>2</sup> Filtering velocity ___ m/s	<input type="checkbox"/> Yes <input type="checkbox"/> No		
			Length (L): Width (W): Height (H): Filter Area Required: $0.4 \times W \times H = \text{___ m}^2$				

- (1) Type of booth: Down-draft, Semi down draft, Cross draft
- (2) For dry filter pad installations, an effective combined pad area for the exhaust of at least 0.4 x booth width x booth height is recommended. If this criterion is not met, the booth must have adequate filtration to allow a filtering velocity between 0.5 to 2.5 m/s.  
Filtering velocity = exhaust flow rate (m<sup>3</sup>/s) / filter area (m<sup>2</sup>)
- (3) Indicate if the booth is equipped with a water wash filtration.
- (4) Refer to diagram for acceptable and unacceptable stack head designs in Appendix C. The Ministry recommends that the stacks are vertical and unimpeded. (i.e. no caps to redirect the exhaust downwards)
- (5) The Ministry recommends a minimum exit velocity of 12 m/s for improve dispersion.  
Exit velocity (m/s) = exhaust flow rate (m<sup>3</sup>/s) / exhaust stack exit area (m<sup>2</sup>).

### 4.2 Associated Equipment Information

(Fill in the following information for all combustion equipment requiring approval, if any)

Source Identifier	Maximum thermal input (KJ/h)	Fuel used (diesel, natural gas, No.2 oil, etc.)

### 4.3 Spray Guns (Fill in the following information for the spray guns)

<b>Provide the make and model of the spray gun(s):</b>	
Type of spray system: (check appropriate box)  <input type="checkbox"/> High Volume Low Pressure (HVLV) <input type="checkbox"/> Low Volume Low Pressure (LVLP) <input type="checkbox"/> Electrostatic <input type="checkbox"/> Conventional Other, specify: _____	Type of Feed:  <input type="checkbox"/> Gravity Feed <input type="checkbox"/> Syphon Feed

## 5.0 NOISE

For single paint spray booth operations, indicate if there are any existing or zoned for future use residential receptors, or any other “Points of Reception” (POR) located within a 100-metre radius of the proposed equipment/facility?  Yes  No

For more than one paint spray booths, indicate if there are any existing or zoned for future use residential receptors, or any other “Points of Reception” located within a 200-metre radius of the proposed equipment/facility?  Yes  No

If the answer is yes to either of the above, please complete Section 5.1 and 5.2.

### 5.1 Booth Fan(s) Information

#### Exhaust Fan and Stack

Source Identifier	Horizontal Distance From stack to nearest POR <sup>(2)</sup>	Stack Diameter (m)	Fan Type <sup>(1)</sup>	Fan Diameter (m)	Rated Capacity (m <sup>3</sup> /s)	Peak Static Pressure (Pa)	Sound <sup>(3)</sup> Power Level (dBA)	Sound <sup>(3)</sup> Pressure Level (dBA at __m)

<sup>(1)</sup> Fan Type includes: Vaneaxial, Tubeaxial, Propeller, Rotary Blower, Centrifugal, Others.

<sup>(2)</sup> Distances to closest Point of Reception- is measured from the top of stack to the property line of the Point of Reception.

<sup>(3)</sup> Useful information (Optional)

#### Intake Fan and Stack

Source Identifier	Horizontal Distance From stack to nearest POR <sup>(2)</sup>	Stack Diameter (m)	Fan Type <sup>(1)</sup>	Fan Diameter (m)	Rated Capacity (m <sup>3</sup> /s)	Peak Static Pressure (Pa)	Sound <sup>(3)</sup> Power Level (dBA)	Sound <sup>(3)</sup> Pressure Level (dBA at __m)

### 5.2 Noise Control Silencer

If the booth fan(s) are equipped with acoustical silencers for controlling noise emissions out of the stack(s), then submit a copy of the manufacturer’s technical specifications and provide the following:

Designation, make and model of silencer(s):								
Rated acoustical performance:								
Centre Frequency (Hz)	63	125	250	500	1000	2000	4000	8000
Insertion Loss (dB)								
<input type="checkbox"/> No Silencer(s) Installed								

## 6.0 DISPERSION MODELLING

Dispersion modelling is the prediction of how emitted material from a facility is diluted as it moves through the atmosphere. Ontario Regulation 419/05 provides details on approved dispersion models that can be used to demonstrate compliance with point of impingement limits.

For automotive refinishing operations, the **Regulation 346 Dispersion Modelling Program** may be used as an approved dispersion model until 2020. More information on other approved dispersion models is available on the Ministry of the Environment Internet site at <http://www.ene.gov.on.ca/envision/air/regulations/localquality.htm>.

A copy of the **Regulation 346 Dispersion Modelling Program** can be obtained at the Ministry of the Environment website at <http://www.ene.gov.on.ca/envision/gp/index.htm#PartAir>

By selecting the Regulation 308/346 Air Model Programs Unpack and Installation Guide, it will guide you through the installation of the program. The user's manual is also available on line.

### 6.1 Regulation 346 - Modelling

For off property receptors the emission could be from a point source if the stack is high enough or a virtual source if emissions are from shorter stacks or vents. If contamination to air intakes or openable windows or doors is an issue for the facility then the Scorer-Barrett equation is used.

*Appendix A of this data form describes the different types of modelling and dispersion calculations. You are strongly encouraged to read over the information prior to completing the following sections.*

Dispersion factors are combined with individual contaminant emission rates to estimate POI concentrations. They are obtained by using a unit emission rate of 1 g/s in modelling for a particular site. This approach can be used for facilities with only one virtual or point source. For more complex modelling scenarios refer to Appendix A. In most circumstances, paint spray facilities would be modelled as one virtual source.

The worst case scenario is modelled using:  Virtual Source  Point Source  
(Please include a copy of the site plan showing the **property line** and the **co-ordinates** used in modelling as well as the modelling output.)

### 6.2 Regulation 346 – Scorer and Barrett Equation

Is the facility housing the equipment shared with other tenants?  Yes  No

If Yes, complete the following: (refer to self contamination in Appendix A of this data form)

- |       |                                                                                                                                                                                |
|-------|--------------------------------------------------------------------------------------------------------------------------------------------------------------------------------|
| (i)   | “Stretched String Distance” from the top of exhaust stack to the nearest “Point of Impingement” of neighbouring unit: _____ m.                                                 |
| (ii)  | Is the “Point of Emission” located above the “Point of Impingement”? <input type="checkbox"/> Yes <input type="checkbox"/> No                                                  |
| (iii) | The calculated dispersion factor at the closest “Point of Impingement” using the Scorer and Barrett Equation is _____ $\mu\text{g}/\text{m}^3$ , based on 1 g/s emission rate. |

Is the facility housing the Equipment located within 5m of the property line?  Yes  No

If Yes, complete the following: (refer to self-contamination in Appendix A)

(i) “Stretched String Distance” from the top of exhaust stack to the property line located within 5 m of the building \_\_\_\_\_ m.

(ii) The dispersion factor (at 1 g/s) at the closest “Point of Impingement” using the Scorer and Barrett Equation is \_\_\_\_\_  $\mu\text{g}/\text{m}^3$ , based on 1 g/s emission rate

### 6.3 Dispersion Factor

*Please note that a dispersion factor is obtained when a generic emission rate of 1 g/s is used in the modelling for a single point or virtual source. Therefore if any emission rate other than 1 g/s is used, skip to Sections 7.0 – 9.0.*

A dispersion factor for a given site is the highest of:

- (i) Virtual Source or Point Source modelling output; (obtained in Section 6.1)
- (ii) Scorer and Barrett dispersion factor for self-contamination, the point of impingement is an air intake, openable window or doorway on a neighbouring unit when the building that houses the spray booth is shared with other tenants (obtained in Section 6.2) **OR**
- (iii) Scorer and Barrett dispersion factor, when the point of impingement is a property line located less than 5 metres from the building which houses the spray booth; (obtained in Section 6.2)

The highest dispersion factor for this application is \_\_\_\_\_  $\mu\text{g}/\text{m}^3$  per g/s, based on a 1 g/s emission rate.



**8.0 SOURCE SUMMARY TABLE:** Complete the following table

Source Identifier	Description	Source Data				Emission Data				
		Stack Gas Flow Rate	Stack Diameter	Stack Height Above Grade	Stack Height Above Roof	Contaminant	Emission Rate	Data Quality	Estimation Technique	Percentage of Overall Emission
		(m <sup>3</sup> /s) (deg°C)	(m)	(m)	(m)		(g/s)			

Note: This Source Summary Table should include all associated combustion equipment (e.g. drying features, air make up units, etc.) and the exhaust parameters for this equipment if the exhausts are separate from that of the booth(s).

## 9.0 EMISSION SUMMARY TABLE

An emission summary table summarizes the total maximum concentrations of pollutants resulting from all sources in a facility. It is used to compare against the POI limits prescribed by the Ministry of the Environment.

For example, if an auto body shop has two paint spray booths, one mixing room and a prep station, the individual Process Emission Summaries show the contaminants emitted from each process in the paint spray booth, mixing room and prep station. However, the Emission Summary Table below summarizes all the contaminant concentrations resulting from each processes combined.

Contaminant Name	CAS	Emission Rate (g/s)	POI Concentration (ug/m <sup>3</sup> )	MOE Criteria (ug/m <sup>3</sup> )	Percent of Criteria

## 10.0 TRAINING (Refer to the training program in accordance with Section 4.3 of the CCME Guideline)

Number of Trained Workers: \_\_\_\_\_

Date of Training Received: \_\_\_\_\_

## 11.0 APPLICATION FEES

According to Regulation 363/98, *Fees for Certificate of Approval*, all applications for Paint Spray Booths must include following:

Code 1, Admin Processing	\$ 200
Code 10, Air Review	\$ 400 for each paint spray booth, prep station
Code 23, Noise Review	\$ 400 for up to five booths at the same site

For auto body shops housing only one paint spray booth, where the horizontal distance from the exhaust fan to the “Point of Reception” is greater than 100 metre,

Code 23, Noise Review fee does not apply. **OR**

For auto body shops housing only one paint spray booth, where the horizontal distance from the exhaust fan to the “Point of Reception” is greater than the minimum set back distance indicated by the MOE Paint Spray Booth Noise Screening Program, Code 23 also does not apply.

Similarly, if a single booth installation is equipped with duct silencers having minimum acoustical performance as shown in Table 1 below and the horizontal distance from the exhaust fan to the “Point of Reception” is more than 10 m, the Code 23 fee may not be submitted with the application. However, if deemed necessary by the reviewer, the fee may be requested later.

TABLE 1 – Minimum Acoustical Performance Values for Duct Silencer

Centre Frequency (Hz)	63	125	250	500	1000	2000	4000	8000
Insertion Loss (dB)	5	10	12	15	15	15	15	15

NOTE: Please be advised that it is the responsibility of the Applicant to provide adequate noise abatement measures to ensure compliance. Some installations may require more effective noise abatement measures than the above minimum equipment.

## DEFINITIONS

**Air Intake Opening** – building air intakes, openable windows, or doorways, on any residential, commercial or industrial building occupied by people not associated with the application.

**CCME Guideline** – the document entitled “National Standards and Guidelines for the Reduction of Volatile Organic Compounds from Canadian Commercial/Industrial Surface Coating Operations-Automotive Refinishing, October 1998, PN 1278”, as amended, and published by the Canadian Council of Ministers of the Environment.

**Dispersion Factor** – it is combined with emission data to calculate POI concentrations. Please refer to Appendix A for details on calculating dispersion factors in dispersion modelling.

**Equipment** – all equipment being associated with an application for a Certificate of Approval under Section 9 of the *EPA*.

**MOE** – Ontario Ministry of the Environment

**Point of Emission** – the point at which a contaminant enters the natural environment

**Point of Impingement** – any point on the ground or on a receptor, such as a nearby building, located outside the company’s property boundaries at which the highest concentration of a contaminant caused by the maximum aggregate emission of that contaminant from a facility is expected to occur.

A point of impingement may be located on the same property as the source of the contaminant if that point is located on a child care facility, or a structure that serves as a health care facility, senior citizens’ residence or long-term healthcare facility, or an educational facility.

**Point of Reception** – any point on the premises of a person where sound or vibration originating from other than those premises is received.

For the purpose of approval of new sources, including verifying compliance with Section 9 of the Environmental Protection Act, the point of reception may be located on any of the following existing or zoned for future use premises: permanent or seasonal residences, hotels/motels, nursing/retirement homes, rental residences, hospitals, camp grounds, and noise sensitive buildings such as schools and places of worship. For equipment/facilities proposed on premises such as nursing/retirement homes, rental residences, hospitals and schools, the point of reception may be located on the same premises.

**Trained** – refers to a training program relating to automotive refinishing operations which conforms with Section 4.3 Training of the CCME Guideline.

<b>Units:</b>	<b>Symbol</b>	<b>Units</b>
	m	metres
	m <sup>2</sup>	square metres
	m/s	metres per second
	m <sup>3</sup> /s	cubic metres per second
	g/s	grams per second
	cfm	cubic feet per minute
	dBA	Decibels, A-weighted
	C	degrees Celsius
	F	degrees Fahrenheit
	µg/m <sup>3</sup>	micrograms per cubic metre
	kJ/h	kilojoules per hour

## APPENDIX A

This section provides a general overview of dispersion modelling and the intent is to help users to complete the emission summary and dispersion modelling report required in this form.

### A 1.0 Introduction

Dispersion models are used to predict pollutant concentrations that would result from any emission source. Based on parameters such as physical features of the source, meteorological conditions, site location, emission duration and emission rates, pollutant concentration estimates can be derived. In order to achieve compliance with the Ministry's Point of Impingement (POI) limits, the emitted maximum contaminant concentrations are evaluated.

### A 2.0 Regulation 346 Modelling Program

The regulatory model used by the MOE is known as the **Regulation 346 Dispersion Modelling Program**. It consists of two mathematical algorithms, Virtual Sources and Point Sources. By inputting required data into the program, it is capable of providing the user with:

- the maximum half-hour ground level concentration at a POI;
- the meteorological condition where the highest concentration occurs; and
- pollutant concentrations at specific POI, such as air intakes, windows and doors of nearby buildings.

### A 2.1 Types of Modelling

Besides Virtual Source and Point Source modelling, the virtual source calculation also specifies modelling for self-contamination. The choice of model is dependent on factors, such as location of POI and the stack height with respect to the maximum building height.

A Virtual Source or a Point Source model is used when the POI is located outside the emission source or the company's property line. The "maximum building height" distinguishes a Point Source from a Virtual Source. The "maximum building height" is the height of the highest point on that building excluding stacks, masts or small structures like elevator penthouses.

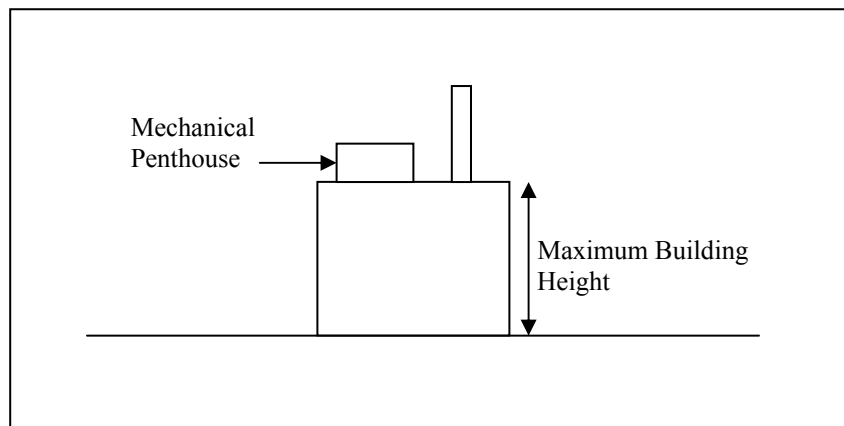

### A 2.1.1 Virtual Sources

The following example illustrates a virtual source:

The stack height above ground is less than twice the maximum building height;

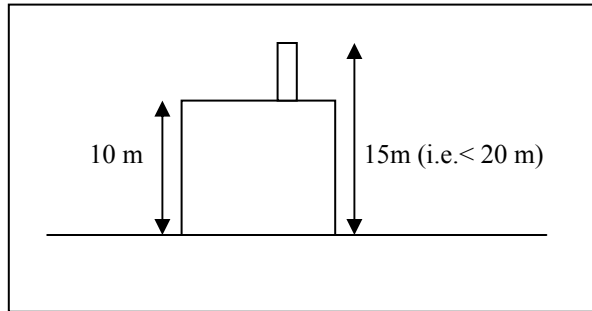

### Location of Emissions

A Virtual Source assumes the emissions are resulting from the centre of the building regardless of the actual location of the sources. The co-ordinates of the virtual source location are where the two diagonals intersect. Important parameters in a virtual source consist of:

- location of the site property line;
- virtual source height (i.e. maximum height of the building);
- contaminant emission rate (unit emission rate of 1g/s, if applicable);
- source width (width of the building);
- source length (length of the building);
- source orientation (see 4.0 for source orientation); and
- x , y co-ordinates (centre of the virtual source as described below)

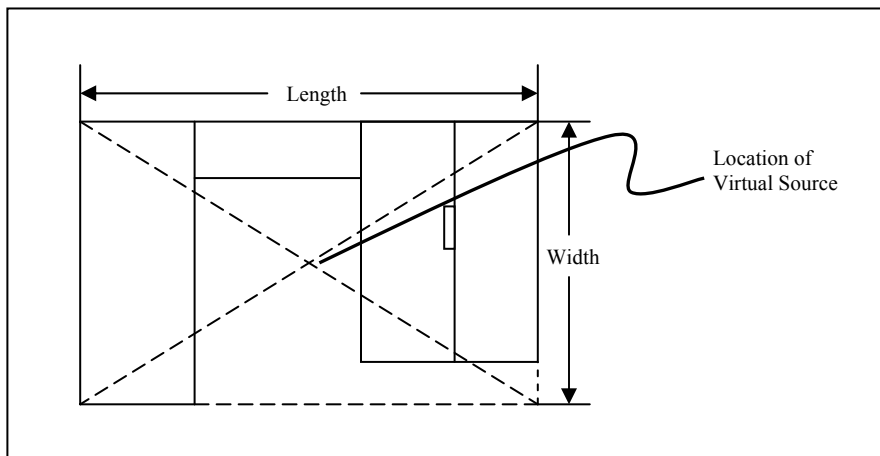

## Single Virtual Source

If there are multiple emission sources on the same building and all the source stacks are less than twice the height of the building, the emissions from these sources can be grouped together as a single virtual source.

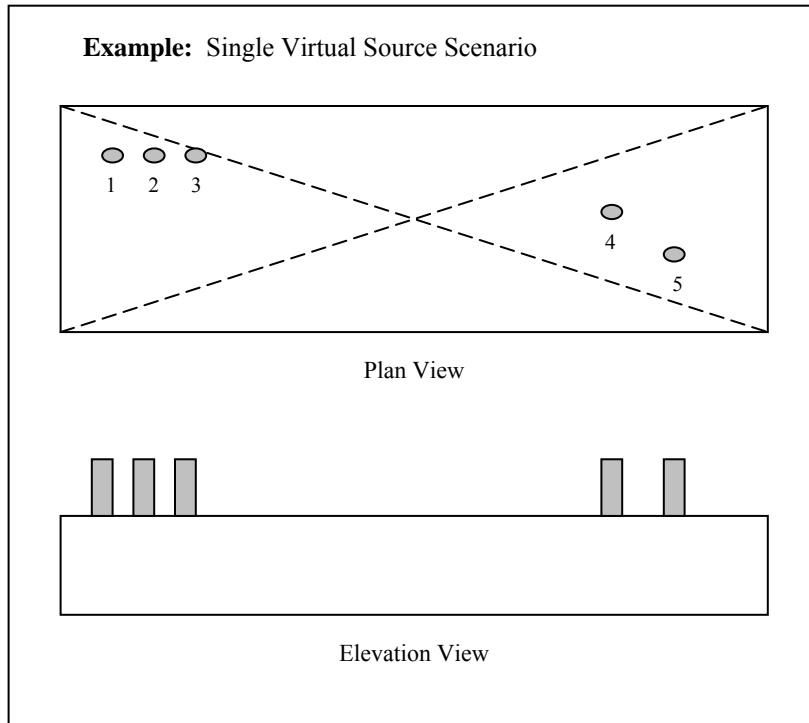

Also, for situations where there is a series of different buildings the dispersion calculation can encompass all those structures as one Virtual Source, provided they are all connected or within 5 metres of each other.

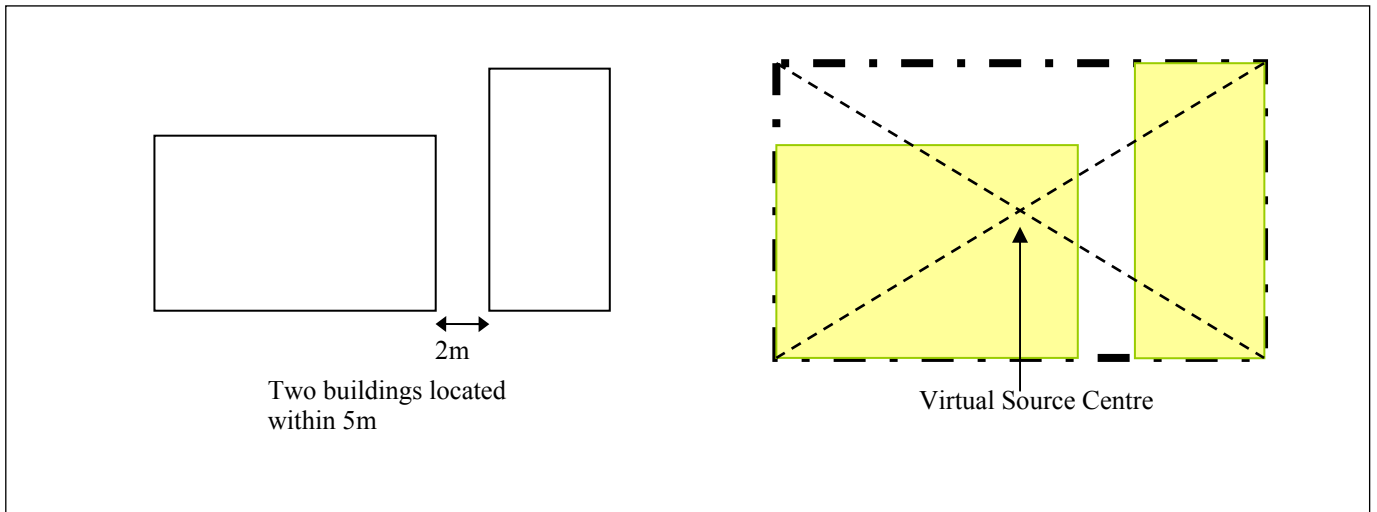

### A 2.1.2 Point Sources

The other type of modelling is a Point Source, illustrated as follows:

- (i) The stack height above ground is more than twice the maximum building height (for buildings less than 20 metres high);

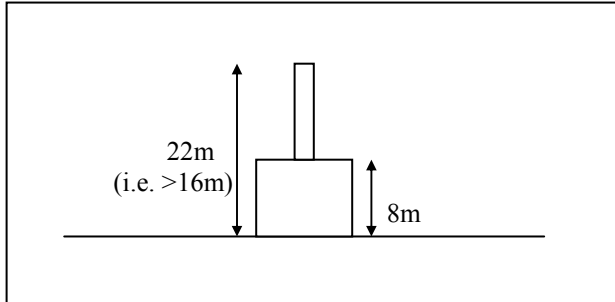

- (ii) For a building greater than 20 metres high, the stack height is more than 20 metres above the roof height;

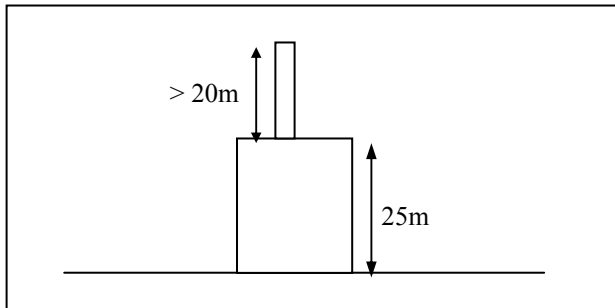

### Location of emissions

In modelling a point source, the co-ordinates relate to the actual stack location. The important parameters are:

- location of property line
- stack height (height of the stack itself);
- contaminant emission rate (exact contaminant emission rate if the unit emission rate is not used);
- exit velocity (exhaust velocity);
- stack diameter;
- stack gas temperature (discharge temperature of exhaust gas);
- x , y co-ordinates of the stack
- location and elevation of any off site receptors that the plume may impact on.

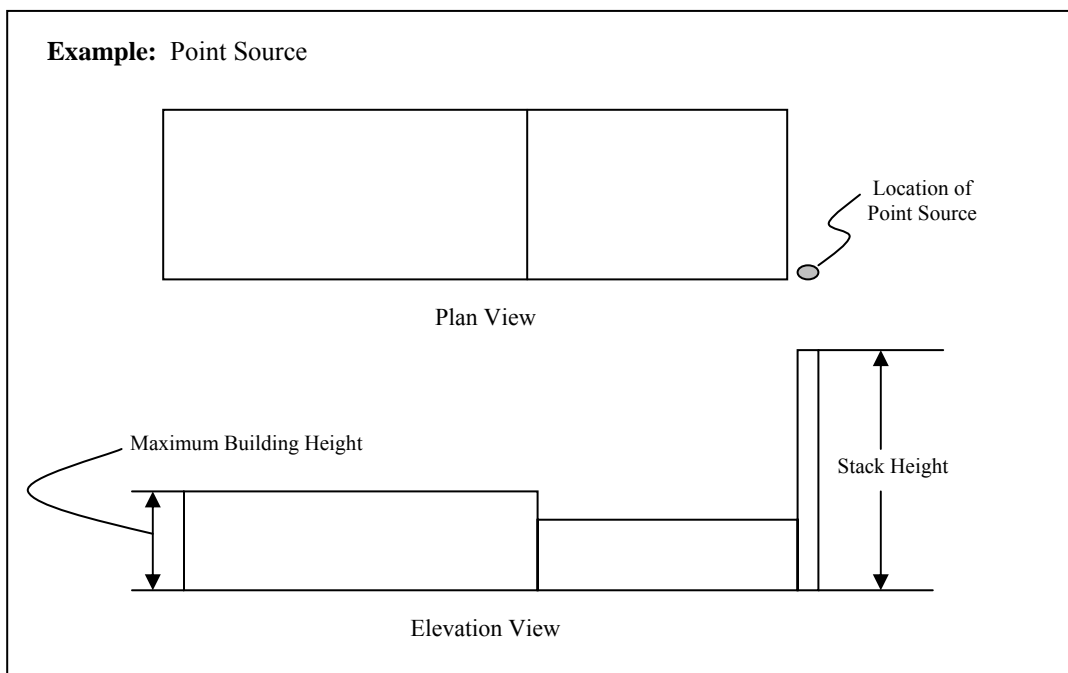

A copy of the **Regulation 346 Dispersion Modelling Program** can be obtained at the Ministry of the Environment website at <http://www.ene.gov.on.ca/envision/gp/index.htm#PartAir>. By selecting the Regulation 308/346 Air Model Programs Unpack and Installation Guide, it will guide you through the installation of the program. The user's manual is also available on line.

## A 2.2 Self-Contamination

The third type of modelling is self-contamination. It differs from most industrial operations since, compliance with the POI limit is required inside the property line of the source. This circumstance arises when the source is in an industrial mall, where contaminants released by tenants at one unit are assessed in terms of their impact on other neighbouring tenants in the building.

The process of estimating the dispersion of contaminant emissions involves using a formula called the **Scorer-Barrett** equation. This simplified calculation provides an estimate of the POI concentrations at neighbouring unit(s) on the source's own building.

POI concentrations depend on the "Stretched String Distance" from the release point of the emission source to the receptor (i.e., an air intake, a doorway or an operable window). The stretched string distance is the shortest distance from the release point to the receptor without intercepting the building. The following illustrates how a stretched string distance is measured at different POIs.

Fresh Air Intake

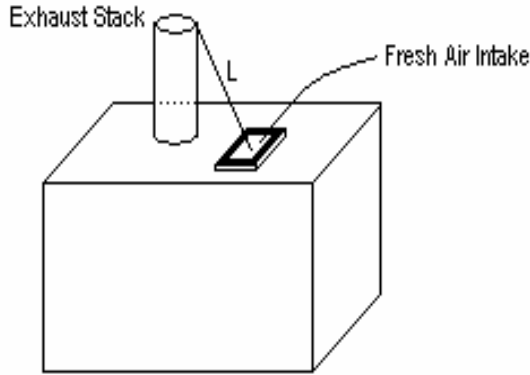

Openable Window/Door on Neighbouring Unit

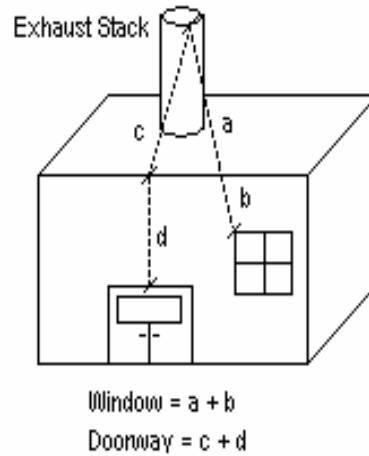

Property Line

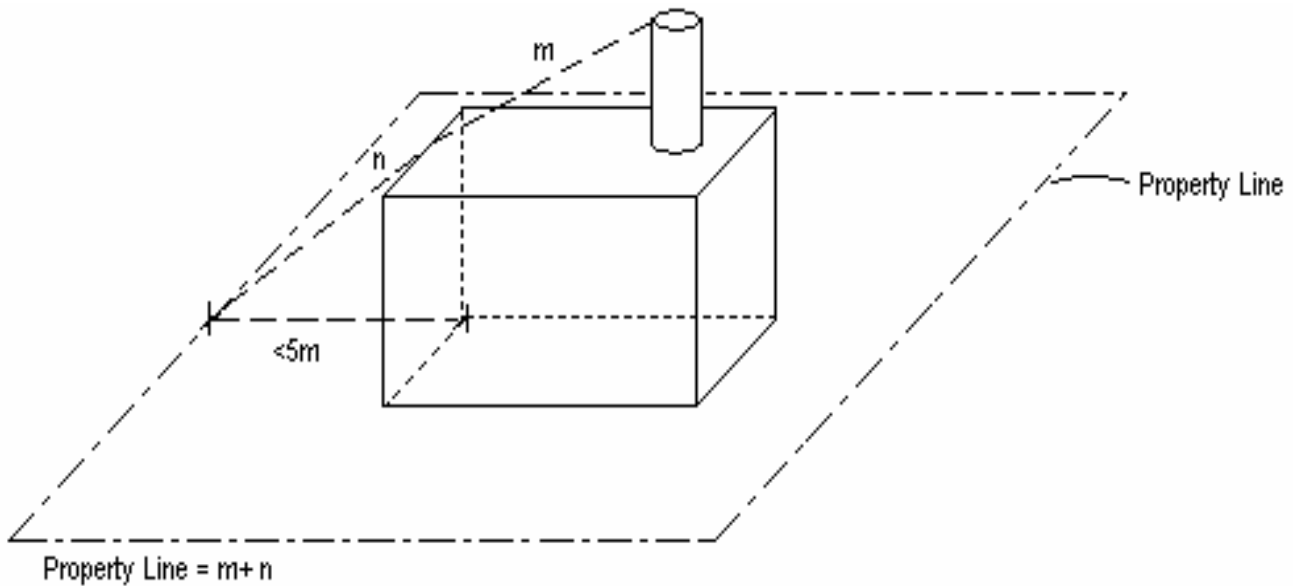

**Scorer and Barrett Equation:**  $K = \frac{0.6 \times 10^6 (Q)}{L^2}$

Equation (A-1)

- Where: K is the half-hour average concentration at the point of impingement in micrograms per cubic metre,  
 Q is the rate of emission in grams per second of the contaminant, (use 1g/s for a unit dispersion factor)  
 L is, (i) where the point of impingement is at the same height or higher above grade than the point of emission, the straight line distance in metres between the point of emission and the point of impingement, or
- (ii) where the point of impingement is lower in height above grade than the point of emission, the product of 1.57 and the straight line distance in metres between the point of emission and the point of impingement.  
 (i.e.  $L = 1.57 \times \text{Stretched String Distance}$ )

When Q equals 1 g/s, K becomes a dispersion factor

## A 2.3 Dispersion Factor

Dispersion factors are combined with individual contaminant emission rates to estimate POI concentrations. They are obtained by using a unit emission rate of 1 g/s in modelling for a particular site. The dispersion factor serves as a multiplier to individual contaminant emission rates to generate POI concentrations. This often simplifies the process of obtaining the POI concentrations. As opposed to performing separate model runs for each individual contaminant, the model would only have to be run once. However, this approach is limited to scenarios with single virtual or point sources.

## A 2.4 Complex Modelling Scenarios

While many industrial facilities can be described as a single virtual source there are many situations where a contaminant is emitted by more than one virtual or point sources or a combination thereof. For these situations, while the same rules apply, the exercise is more complicated. When there is more than one distinct virtual or point source that is emitting the contaminant, a unit emission rate of 1 g/s cannot be used. The dispersion modelling exercise must be carried out for all the sources together and repeated for each individual contaminant.

## A 3.0 Emission Rates

Emission rates must be calculated carefully since compliance of the POI concentration with the Ministry's limit is dependent on it. The suggested approach that should be used is the "Mass Balance" method.

### A 3.1 Maximum Emission Scenario (Worst Case Scenario)

The maximum emission scenario occurs when all sources of emissions are considered operating simultaneously, including periodic releases. Each and every source at the facility shall be considered regardless of when a source was installed or whether or not approval under Section 9 of the Environmental Protection Act was obtained for that source. The POI concentration is then calculated for the maximum aggregate emission rate of a given contaminant for the worst half hour time period.

### A 3.2 Mass Balance Approach

A "Mass Balance" is an accounting of the material that enters and leaves from a process. In the surface coating process, it accounts for the amount of paint sprayed on the job and the amount that leaves the exhaust stack.

#### **Example:**

An autobody paint spray booth uses a clear coat that is comprised of 80% Clear and 20% Hardener. Among the many contaminants that make up these products, xylene is one of the contaminants found in both products. As indicated on the respective MSDS, xylene accounts for 40% by weight of the Clear and 30% by weight of the Hardener. The maximum application rate is 2 litres per hour.

Net input of the Clear = 2 L/hr x 80% = 1.6 L/hr

Net input of the Hardener = 2 L/hr x 20% = 0.4 L/hr

The Clear weighs 936 g/L and so 1497.6 g of Clear is used in an hour or 0.416 g/s.

(i.e. Mass of Clear = 1.6 L/hr x 936 g/L = 1497.6 g/hr **or** 1497.6 g/hr / 3600 s/hr = 0.416 g/s)

Since 40% of the Clear is xylene, the emission rate of xylene from the Clear is 0.166 g/s.

(i.e. Mass of xylene in Clear = 0.416 g/s x 0.4 = 0.166 g/s)

Following the same calculation, the Hardener which weighs 1069 g/L gives an overall emission rate of 0.119 g/s and 0.0356 g/s of xylene is emitted.

(i.e. Mass of Hardener = 0.4 L/hr x 1069 g/L = 427.6 g/hr **or** 427.6 g/hr / 3600 s/hr = 0.119 g/s

Mass of xylene in Hardener = 0.119 g/s x 0.3 = 0.0356 g/s )

For the maximum emission scenario, 100% of all volatile organic compounds are emitted into the environment. Therefore, the total xylene emission rate is, 0.166 + 0.0356 = 0.202 g/s

By multiplying the emission rate with the dispersion factor, a POI concentration is obtained.

## A 4.0 Source Orientations

In the **Regulation 346 Dispersion Model**, the source orientation is defined with respect to the x-axis in a Cartesian co-ordinate system. The length is defined as the longer side of the virtual source and the width is the shorter side. The source orientation is measured as the angle between the x-axis and the Virtual Source length in a counter-clockwise direction.

The first diagram below shows a building with the length parallel to the x-axis. This would be considered as having a building orientation angle of zero degrees ( $0^\circ$ , no rotation). The second diagram shows a building rotated counter-clockwise from the x-axis at  $90^\circ$ . The building length is now parallel to the y-axis. The next two drawings show buildings that are of a different shape. The length and width is defined by drawing the smallest rectangle that encompasses the structure (using the dotted lines). Again, the source orientation is the angle between the x-axis and the length of the virtual source, counter-clockwise from the x-axis.

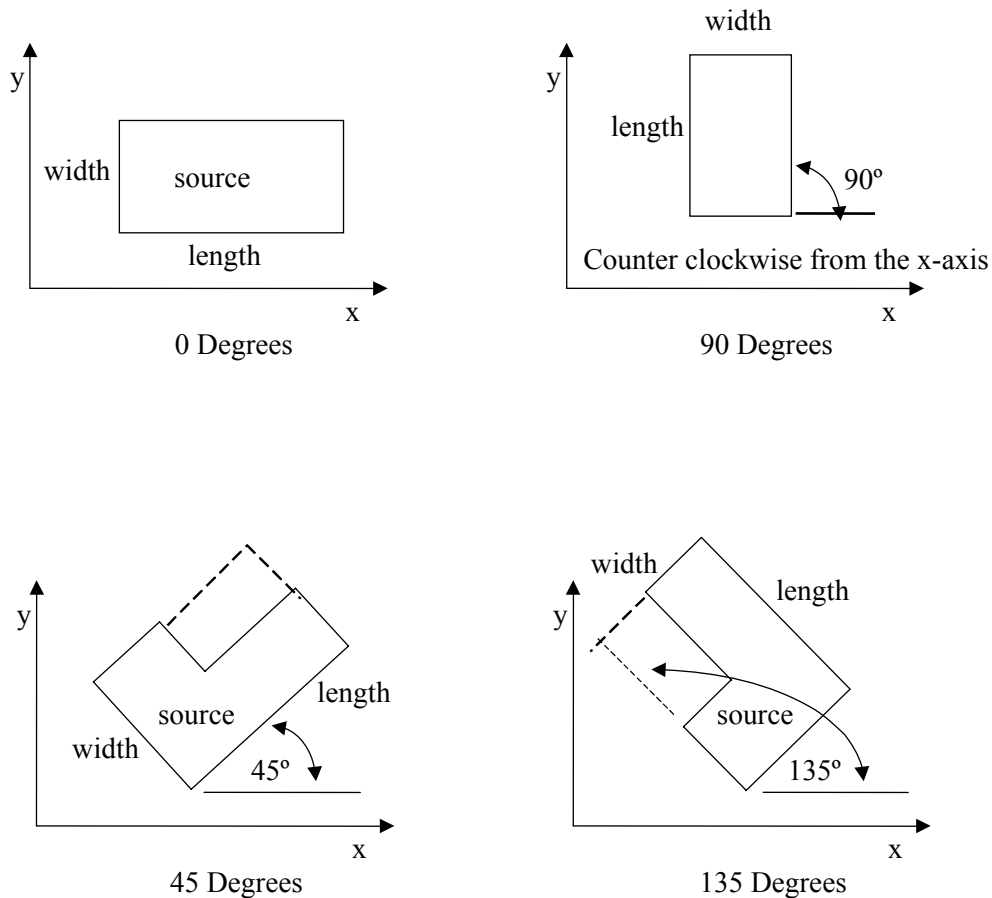

## APPENDIX B

The **Process Emission Summary** contains all the contaminant emissions resulting from a particular process in the painting operation. These processes include, but are not limited to, priming, base coating and clear coating. The following table describes what should be included in a Process Emission Summary and how emission concentrations are calculated. The user should pay special attention to the following key points:

- (1) All volatile organic compounds (VOCs) that appear on the MSDS of the paint used, including those that do not have a published POI limit, must be listed in the summary;
- (2) During the spraying operation, 100% of VOCs are emitted into the environment;
- (3) To reflect the maximum emission scenario, the highest volume percentage should be used in the percentage range given on an MSDS;
- (4) The Ministry has identified a potential concern with isocyanates emissions. For the current screening procedure for isocyanates, please refer to the publication titled “Emission Factors for 1, 6 – Hexamethylene Diisocyanate (HDI) Emissions from Spray Booth Operations”. This document is available on the Ministry of the Environment Internet site at: <http://www.ene.gov.on.ca/envision/techdocs/5565e-tb.pdf>.
- (5) A separate **Process Emission Summary** is required for each process. For all contaminants that occur in more than one operation simultaneously, the total emissions are summarized in the **Emission Summary Table**; and
- (6) It is the proponent’s responsibility to demonstrate compliance with the Ministry’s published guideline limits.

### Process Emission Summary

Name of Company:	<b>1</b>	Dispersion Factor =	0	(µg/m <sup>3</sup> at 1 g/s)	← 12
Date:	<b>1</b>	Process:			← 2
Prepared By:	<b>1</b>	Application Rate =	a	L/hr	← 3

Component Composition				
Maximum				
	Paint	Reducer	Hardener	
Product Code	M	N	O	← 4
Mix Ratio	b	c	d	← 5
Mix Spray Rate (L/hr)	SR <sub>M</sub>	SR <sub>N</sub>	SR <sub>O</sub>	← 6
Mix Density (g/L)	D <sub>M</sub>	D <sub>N</sub>	D <sub>O</sub>	← 7

Individual Contaminant Name	CAS #	Max %	Max %	Max %	Emission Rate (g/s)	POI (µg/m <sup>3</sup> )	POI Limit (µg/m <sup>3</sup> )	Effect	% of Criteria
<b>8</b>	<b>9</b>		<b>10</b>		<b>11</b>	<b>13</b>	<b>14</b>		

The following notes correspond to the numbers in the above sample spreadsheet:

**Note 1:** This includes the name of the company, date of preparation, and author of the spreadsheet.

**Note 2:** This represents the different stages in a painting operation, such as priming, basecoating, clearcoating, etc.

**Note 3:** This is the maximum application rate in any ½-hour time period (in L/hr), not the capacity of the spray gun. Consider the amount of paint required to be applied on the largest typical job.

**Example 1: Maximum Application Rate**

An autobody shop receives painting jobs for different sizes and colours of vehicles. For the largest job that the company will receive, it takes a trained worker 2 hours to apply 2 litres of paint in a manner described as follows.

In the first half hour, 1 litre of paint is applied and there is a flash off period of 15 minutes. Then another 0.5 litre of paint is applied over half an hour and it is allowed for flashing for another 15 minutes. The last 0.5 litre is applied in the remainder half hour, which comes to a total time period of 2 hours.

The greatest paint application rate during the 2-hour period occurred in the first half hour of the process, consuming 1 litre of paint. Therefore, the maximum application rate is 2 litres per hour. Although the total amount of paint used was 2 litres over the 2-hour period, the maximum application rate is not 1.0 L/hr.

**Example 2: Application rate less than half an hour**

In the case where the emission takes place over less than half an hour, it is permissible to average over the half-hour.

In a small auto refinishing shop, the largest job would only take 0.5 litre of paint to be applied continuously over a 15 minute period but emitted nothing for the next 24 hours. The maximum application rate is 2 litres per hour. However, it is permissible to average the total 0.5 litre over 30 minutes to obtain 1.0 litre per hour.

**\* Note that it is not acceptable to divide the annual paint consumption by the number of hours worked in a year to obtain an hourly rate.**

Since the proponent will be restricted to using the maximum application rate on the Certificate of Approval, it is important to calculate this carefully.

**Note 4:** This is the product code for the paint mixture used in a particular process. If more than one paint mixture is used, spreadsheet(s) must represent the product used most and those containing that most toxic or hazardous contaminants. All products that include isocyanates must be reported.

**Note 5:** The ratio of paint products included in the final paint mixture. This is usually given by the manufacturer's specification sheet.

**e.g.** The paint mixture containing 3 litres of clearcoat, 2 litres of hardener, and 1 litre of reducer has a mixing ratio of 3:2:1

**Note 6:** This is the spray rate (SR) for each component in a product, calculated by multiplying the individual mix ratios with the maximum application rate as follows:

**Example 3: Component Spray Rate Calculation**

Component spray rate (L/s) = Paint component ratio \* Maximum application rate (L/s)

e.g. Maximum application rate = 2 L/s

Ratio of clearcoat in mixture = 3 litres of clearcoat in a 6 litres paint mixture

Component spray rate for clearcoat = (3/6) \* 2 L/s = 1 L/s

\* The sum of the component spray rates should equal the maximum application rate.

**Note 7:** This is the density of the paint used. An MSDS provides either the specific gravity or the density of the paint in the physical and chemical properties section. If the specific gravity is provided, it can be converted to the density as follows:

#### **Example 4: Paint density Calculation**

In the physical and chemical properties of a MSDS, it shows the specific gravity of the product being 1.040. The paint density is then,

$$\begin{aligned}\text{Paint density (g/L)} &= \text{Specific Gravity} * 1000 \text{ g/L} \\ &= 1.040 * 1000 \text{ g/L} \\ &= 1040 \text{ g/L}\end{aligned}$$

Therefore, 1040 g/L is entered into section 7 of the spreadsheet.

**Note 8:** Please enter the contaminant name as it appears in the hazardous ingredients section on an MSDS

**Note 9:** The Chemical Abstract Service (CAS) number is a system used to identify the chemical name or chemical structure for a contaminant. This can be found in the hazardous ingredient section on an MSDS (e.g. Xylene CAS number is 1330-20-7)

**Note 10:** This is the maximum percent composition for each contaminant in a product. It is found in the hazardous ingredients section on a MSDS. The highest number out of the percentage range should be used in all cases.

e.g. The percentage composition for Xylene in a product can range from 30%-50%. Therefore 50% should be used in the emission summary.

**Note 11:** This is the maximum emission rate of a particular contaminant. Refer to Section 3.0 in Appendix A for more explanation.

#### **Example 5: Emission Rate Calculation**

A particular painting process uses a paint mixture that contains a clearcoat and a hardener. The contaminant n-butyl acetate is common in both paints. In order to obtain the maximum POI concentration for n-butyl acetate, the contaminant emission rate must be calculated.

$$\begin{aligned}\text{Emission Rate for n-butyl acetate (g/s):} \\ &= \text{Clearcoat spray rate} * \text{Clearcoat density} * \% \text{ n-butyl acetate in Clearcoat} + \\ &\quad \text{Hardener spray rate} * \text{Hardener density} * \% \text{ n-butyl acetate in Hardener}\end{aligned}$$

For example:

The maximum spray rate is 2 L/hr. The paint mixture contains clearcoat and hardener mixed in 2:1 ratio.

The component spray rates are:

$$\text{Clearcoat spray rate} = 2 \text{ L/hr} \times (2/3) = 1.33 \text{ L/hr}$$

$$\text{Hardener spray rate} = 2 \text{ L/hr} \times (1/3) = 0.66 \text{ L/hr}$$

The MSDS shows that the Clearcoat has a density of 1040 g/L and Hardener has a density of 970 g/L. Also the Clearcoat and the Hardener contains 30% and 50% n-butyl acetate, respectively.

The Emission rate for n-butyl acetate is then

$$= (1.33 \text{ L/hr} * 1040 \text{ g/L} * 30\% + 0.66 \text{ L/hr} * 970 \text{ g/L} * 50\%) / 3600 \text{ s/hr} = \underline{0.204 \text{ g/s}}$$

**Note 12:** Dispersion factor is generated from dispersion modelling when a unit emission rate of 1 g/s is assumed in the modelling. See Section 2.3 for details.

**Note 13:** The “POI” concentration is the product of a dispersion factor and an emission rate. If a dispersion factor was not used, the POI concentration should reflect the results of the modelling output for each contaminant.

**Note 14:** “POI limits” – The Ministry of the Environment has established a document *entitled “Summary of O. Reg. 419/05 Standards and Point of Impingement Guidelines and Ambient Air Quality Criteria (AAQCs) (December 2005)”* It lists the maximum Point of Impingement contaminant concentrations allowed based on a facility’s combined emissions of that contaminant from all sources. This document can be obtained from “Publications” section of the Ministry of the Environment website: <http://www.ene.gov.on.ca/> or by calling the Environmental Assessment and Approvals Branch at (416) 314-8001 or 1-800-461-6290.

“% of criteria” – contaminant concentration expressed as a percentage of the applicable POI. Compliance is achieved when the percent of criteria is below 100%.

## Appendix C

The following diagrams illustrate various stack head designs for the exhaust stack. Guideline criteria also require that the exhaust stack be vertical to provide proper dispersion of the exhaust plume.

Deviation from the recommended stack head designs, vertical discharge and/or exit velocity criteria (outlined in page 2 of this form) must include a detail analysis demonstrating compliance.

### Recommended Designs



Straight

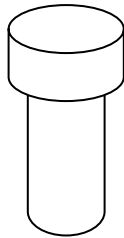

Rain Ring



Cone

### Not Recommended

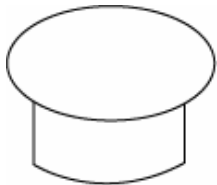

Mushroom

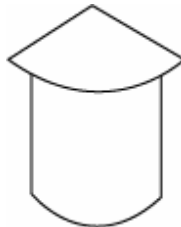

Chinese Hat

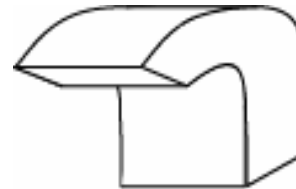

Elbow